

HNESS SERIES



Utility Storage System

Energy Storage Compartment:

BMS / Battery / Liquid Temperature Control / Fire Protection System

PRODUCT ADVANTAGES



Optimal Safety and Reliability

Full life-cycle cell state monitoring + cell-level thermal isolation with sequential melting fuses.

Coordinated protection with proactive cell health monitoring + three-level fire protection.



Superior Efficient and Versatility

Intelligent liquid-cooled temperature control for long system life, with low auxiliary power consumption.

Stackable design, adaptable to various types of PCS.



High Energy Density

Modular design for a rational layout and easy maintenance. 20-foot standard container, high energy density, convenient for loading, unloading, transportation, and installation.



Intelligent O&M

All-in-one integration.

Extremely low-frequency fluid injection.

User-friendly cloud monitoring for easy operation.

TOPOLOGY STRUCTURE

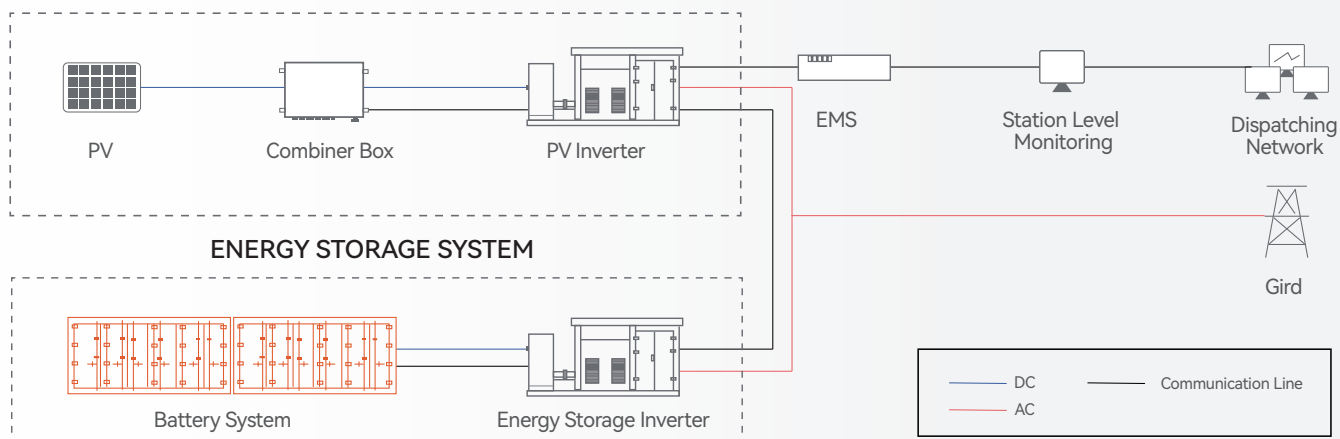

PRODUCT PARAMETER

MODEL

HNESS 3420-20H

HNESS 5000-20H(Customizable)

Specification

Cell Capacity	LFP 300Ah	LFP 314Ah
Rated Capacity	3421.4kWh	5015.96kWh
Rated Voltage	1267V	1331.2V
Recommend. Voltage Range	1108.8V-1425.6V	1164.8V~1500.0V
Max.charge /discharge Rate	0.5P@25°C	0.5P@25°C
Power	1710.7kW	2507.98kW

Environment

Working Temperature Range	-30~45°C	-20~+55°C
Working Humidity Range	0-95 %, RH	0%-95%, RH
Ingress Protection	IP54	IP54
Cooling	Liquid	Liquid
Fire Control System	Heptafluoropropane / Perfluorohexanone	Aerosol + water spray
Altitude	< 3000m	≤2000m
Cycle times	≥6000@25°C	≥6000@25°C

Standards

Safety	IEC62619、IEC62477、IEC61000、IEC60730、IEC62933、GB/T 36276	/
Transport	UN38.3	/
Communication	CAN、RS485、Ethernet	Ethernet/RS485/CAN

Structure

Size (W*D*H)	6058mm*2438mm*2896mm	6058*2438*2896mm
Weight	≈ 37t	≈ 43t

WARRANTY

5 YEARS

≥ 6000 CYCLES